

# Genetic Engineering of Potyvirus Resistance Using Constructs Derived from the Zucchini Yellow Mosaic Virus Coat Protein Gene

Guowei Fang and Rebecca Grumet

Department of Horticulture, Michigan State University, East Lansing, 48824 U.S.A.  
Received 21 October 1992. Accepted 26 January 1993.

Three versions of the zucchini yellow mosaic virus (ZYMV) coat protein gene were engineered for expression in plants: the full-length coat protein sequence, the conserved core portion of the gene, and an antisense version. These constructs were introduced into muskmelon (*Cucumis melo*) and tobacco plants (*Nicotiana tabacum*) via *Agrobacterium tumefaciens*-mediated transformation; gene expression was verified by Northern and Western analysis. Transgenic R<sub>0</sub> and R<sub>1</sub> muskmelon plants expressing the full-length coat protein gene exhibited apparent immunity to ZYMV infection: There was a lack of symptom development during a 3-mo observation period and no measurable virus accumulation as determined by ELISA. Melon plants expressing the core or antisense constructs showed a several-day delay of systemic symptom development and reduction in virus titer. Furthermore, transgenic R<sub>1</sub> tobacco plants expressing the full-length coat protein, core, or antisense constructs of ZYMV, a nonpathogen of tobacco, showed a short delay in symptom development and reduced virus titer when inoculated with the heterologous potyviruses, potato virus Y, and tobacco etch virus. The transgenic tobacco plants were not protected against the nonpotyvirus, tobacco mosaic virus.

*Additional keywords:* coat protein-mediated resistance, pathogen-derived resistance.

Genetically engineered coat protein (CP)-mediated protection has been used to develop resistance to viruses in several virus groups (for review see Beachy *et al.* 1990; Grumet 1990; Nelson *et al.* 1990). In most examples, transgenic plants expressing the CP gene from a given virus were protected against infection by that virus (homologous virus). Virus-inoculated leaves of the transgenic plants showed fewer chlorotic or necrotic lesions relative to control plants, and systemic spread of infection was either prevented, delayed, or reduced. CP-mediated pro-

tection also has been demonstrated to extend to related strains or viruses (heterologous viruses). For example, the CP of tobacco mosaic virus (TMV) U1 strain protects against infection by the severe strain of TMV, PV230 (Nelson *et al.* 1987), and against some other tobamoviruses (Nejdat and Beachy 1990). Expression of the CP genes of the potyviruses soybean mosaic virus, papaya ringspot virus, watermelon mosaic virus 2, and zucchini yellow mosaic virus in transgenic tobacco plants (*Nicotiana tabacum* and *N. benthamiana*) conferred varying levels of protection against infection by other potyviruses (Stark and Beachy 1989; Ling *et al.* 1991; Namba *et al.* 1992).

Cucurbit yields are often severely limited because of infection by three potyviruses, the watermelon strain of papaya ringspot virus (PRV-W), watermelon mosaic virus 2 (WMV-2), and zucchini yellow mosaic virus (ZYMV). Among these, ZYMV is a relatively new but very aggressive member of the potyvirus group that has spread rapidly throughout the world since it was first described in 1981 (Lisa *et al.* 1981; Davis and Mizuki 1985). The ZYMV coat protein gene has been cloned, and the nucleic acid sequence has been determined in several laboratories (Grumet and Fang 1990; Gal-On *et al.* 1990; Quemada *et al.* 1990). The gene encodes a coat protein with 279 amino acids and a calculated molecular mass of 31,214 Da. Sequence comparison shows that ZYMV shares an average of 50–60% amino acid sequence homology in the CP with other potyviral CPs. The majority of the conserved amino acids are located in the central- and carboxy-terminal region of the protein, known as the trypsin-resistant core portion of potyviral CPs (Shukla *et al.* 1988).

In our efforts to genetically engineer potyvirus resistance, to test for protection against both homologous and heterologous viruses, and to gain insight into possible mechanisms of protection, we utilized three versions of the ZYMV CP gene: the full-length CP gene, a truncated core portion of the CP gene, and an antisense version of the CP gene. The full-length CP gene was used because incorporation and expression of viral capsid protein genes has provided the strongest virus resistance in most reported examples of engineered resistance (Beachy *et al.* 1990; Grumet 1990). The truncated version of the CP gene including the highly conserved central- and carboxy-terminal region (the core portion) was also of interest. Since the RNA binding capacity and coat protein-coat protein interactions involved in virus assembly are contained within the highly conserved core portion of the gene (Dougherty

Address correspondence to: R. Grumet, Department of Horticulture, Michigan State University, East Lansing, Michigan 48824 MI, U.S.A.

Current address of Guowei Fang: Department of Botany and Plant Pathology, Michigan State University, East Lansing, 48824 U.S.A.

et al. 1985; Shukla and Ward 1989a; Shukla et al. 1988), we thought that the core portion alone might be sufficient to confer resistance. Furthermore, it might be possible that plants expressing the conserved CP gene fragment could be protected from infection by more than one potyvirus. The first tests of CP-mediated protection using a truncated viral CP gene were reported recently (Lindbo and Dougherty 1992). Plants expressing a truncated tobacco etch virus (TEV) CP gene lacking the carboxy terminus exhibited higher levels of protection against TEV infection than did plants expressing full-length CP.

This paper describes the engineering and introduction of the three ZYMV CP-derived constructs into melon and tobacco plants and the effect of those constructs on increasing resistance to infection by ZYMV and two heterologous potyviruses, TEV and potato virus Y (PVY).

## RESULTS

### Plant transformation.

The *Agrobacterium tumefaciens* binary transformation system was used to introduce the ZYMV CP constructs into muskmelon and tobacco plants. Approximately 45%

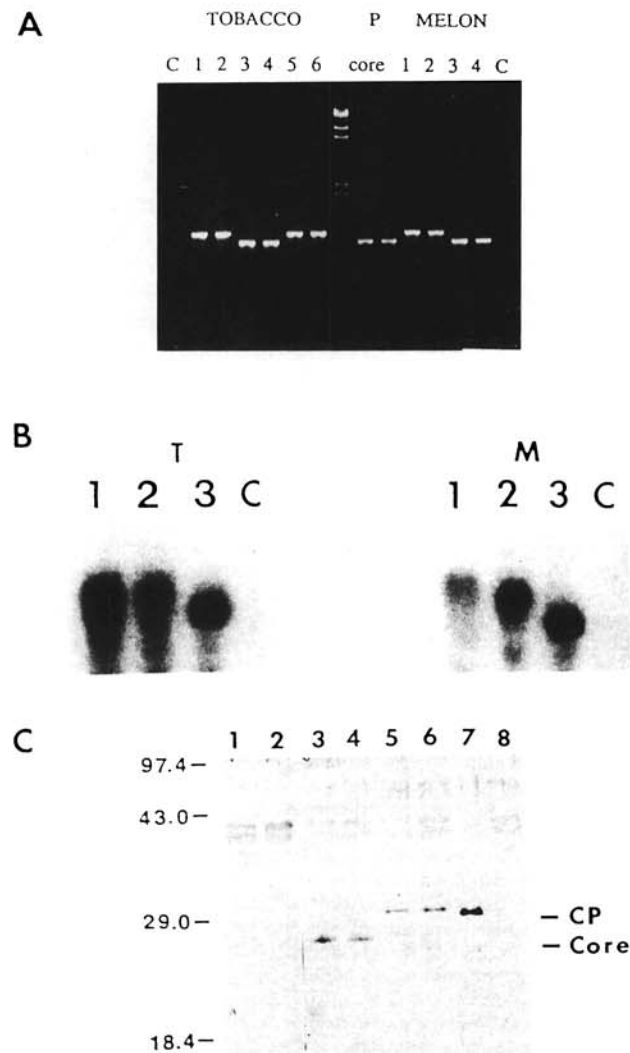

Fig. 1. Verification of introduction and expression of the zucchini yellow mosaic virus coat protein (ZYMV-CP) gene constructs. **A**, Polymerase chain reaction (PCR)-amplified ZYMV-CP DNA fragments from transgenic tobacco (T) and melon (M) plants. The samples from left to right are: lane T-C, vector-only transformed tobacco plant; lanes T-1 and 2, full length-coat protein (FL-CP)-transformed tobacco plants; lanes T-3 and 4, Core transformed tobacco plants; lanes T-5 and 6, antisense (AS) tobacco plants; lanes P, plasmid pCIB710+Core; lane M-1, ZYMV-AS transformed melon plant 103; lane M-2, FL-CP transformed melon plant 401; lanes M-3 and 4, Core-transformed melon plants 310 and 323; and lane M-C vector-only transformed melon plant. The ZYMV FL-CP and AS fragments were approximately 1.2 kbp, and the ZYMV Core fragment was approximately 1.1 kbp. **B**, Accumulation of transcripts of CP gene constructs in transgenic plants. The Northern blot was loaded with 10 µg of total RNA isolated from leaves of transgenic tobacco (T) and melon (M) plants. Lane T-1, AS-transformed tobacco plant; lane T-2, FL-CP tobacco plant; lane T-3, Core tobacco plant; lane T-C, vector-only transformed control plant; lane M-1, AS-transformed melon plant 106; lane M-2, FL-CP melon plant 401; lane M-3, Core melon plant 301; and lane M-C, vector-only transformed melon plant. The blot was hybridized with <sup>32</sup>P-labeled cDNA corresponding to the ZYMV CP gene. **C**, Detection of ZYMV-CP and Core proteins in transgenic R<sub>0</sub> melon plants. Total soluble protein was isolated from leaf samples of transgenic plants. Fifty micrograms of total protein was separated on a 10% sodium dodecyl sulfate polyacrylamide gel, transferred to nitrocellulose, treated with rabbit antibody against ZYMV CP and alkaline phosphatase-conjugated goat anti-rabbit secondary antibody. Lanes 1 and 2 contain protein from AS-transformed plants 103 and 106; lanes 3 and 4 are Core plants, 310 and 323; lanes 5 and 6 are FL-CP transformed plants, 401 and 207; lane 7 contains 20 ng of purified ZYMV CP; lane 8 is a vector-only transformed plant. The full-length coat protein is approximately 30 kDa, the Core protein is about 26 kDa. When detected in total soluble protein preparations, viral and engineered ZYMV-CP both migrate to the same position (data not shown), and somewhat more slowly than the purified ZYMV-CP.

of the muskmelon plants regenerated in the presence of kanamycin tested positive for NPT II expression by ELISA. More than 80% of the kanamycin-resistant tobacco regenerants were found to be NPT II-positive. The expected ZYMV CP fragments were amplified by PCR from more than 90% of the NPT-positive melon and tobacco plants (Fig. 1A). Most of the regenerated melon and tobacco plants appeared healthy, were morphologically normal, and produced typical flowers and seeds. No symptoms typical of ZYMV or other viruses, such as mosaic or etching of the leaves, were observed on noninoculated, regenerated plants. Occasionally R<sub>1</sub> melon progeny had elongated first true leaves, but normal subsequent leaves.

### Expression of ZYMV coat protein gene constructs in transformed plants.

Transcripts of the ZYMV CP constructs were examined by Northern analysis (Fig. 1B). Strongly hybridizing bands were observed in transgenic tobacco (T) and melon (M) plants (lane T1, T2, T3, M1, M2, and M3) that had been transformed with either the FL-CP, Core, or AS version of the ZYMV CP gene. The control, vector-transformed plants did not give any signal (lane C). The estimated size of the specific transcripts produced by plants transformed by the FL-CP gene (both sense and antisense) was 1.2 kb (lane T1, T2, M1, and M2). This compares well with the size of the RNA expected: 150 bases of TEV 5' NTR, 830 bases of ZYMV FL-CP sequence, and 211 bases of

ZYMV 3' NTR plus the poly(A) tail. The ZYMV Core construct transformed plants showed the expected bands of approximately 1.1 kb (lanes T3 and M3). Fourteen of fifteen tested transgenic tobacco plants (NPT positive, PCR positive) and all eight tested transgenic melon plants (NPT positive, PCR positive) produced detectable RNA bands of the expected size. The levels of transcript varied from plant to plant; however, the range of transcript levels observed was comparable for sense and antisense expressing plants.

Twenty-two transgenic tobacco plants and 13 transgenic melon plants were tested by Western analysis for the presence of ZYMV coat protein. Representative melon samples and controls are shown in Figure 1C. Accumulation of detectable amounts (detection limit = 5 ng) of viral protein of the expected size (about 30 kDa for FL-CP and 26 kDa for Core) was found in three of eight tobacco plants

and two of five melon plants transformed with the sense FL-CP gene, and five of eight tobacco plants and four of five melon plants transformed with the core fragment. The level of ZYMV FL-CP or core protein ranged from below 0.01% (detection limit) up to 0.05% of total extracted protein and was comparable for melon and tobacco plants. This is within the range that has been reported for engineered viral coat protein genes in other transgenic plants (Beachy *et al.* 1990; Grumet 1990). On average, levels of protein expression were at least as high, or higher, for Core than for FL-CP plants. None of the eight tested tobacco plants nor the three melon plants transformed with the ZYMV AS construct produced detectable ZYMV coat protein.

### Segregation analysis of the inserted genes in the progeny of transgenic plants.

Progeny of self-fertilized transgenic tobacco plants were analyzed by ELISA for the presence of the NPT II gene. Progeny of most of the nine tested lines segregated with a ratio of 3:1 (NPT<sup>+</sup>:NPT<sup>-</sup>, data not shown), indicating that the NPT gene was expressing from a single locus. There were two lines with a segregation ratio of 15:1 (NPT<sup>+</sup>:NPT<sup>-</sup>), suggesting that the NPT II gene was expressing from two loci. All four lines of transgenic melon tested (Core 310, Core 410, FL-CP 207, and FL-CP 401) had NPT II segregation ratios suggesting more than one insertion.

### Protection against ZYMV infection in transgenic melon plants.

All of the ZYMV-inoculated, nontransformed melon plants showed symptoms 10 days after inoculation (Fig. 2A, B). Infected leaves exhibited severe mosaic symptoms, and the growth of infected plants was greatly reduced. All younger leaves and shoots displayed disease symptoms. Symptom development in vector-only transformed control plants, which had only the NPT II gene, was equivalent

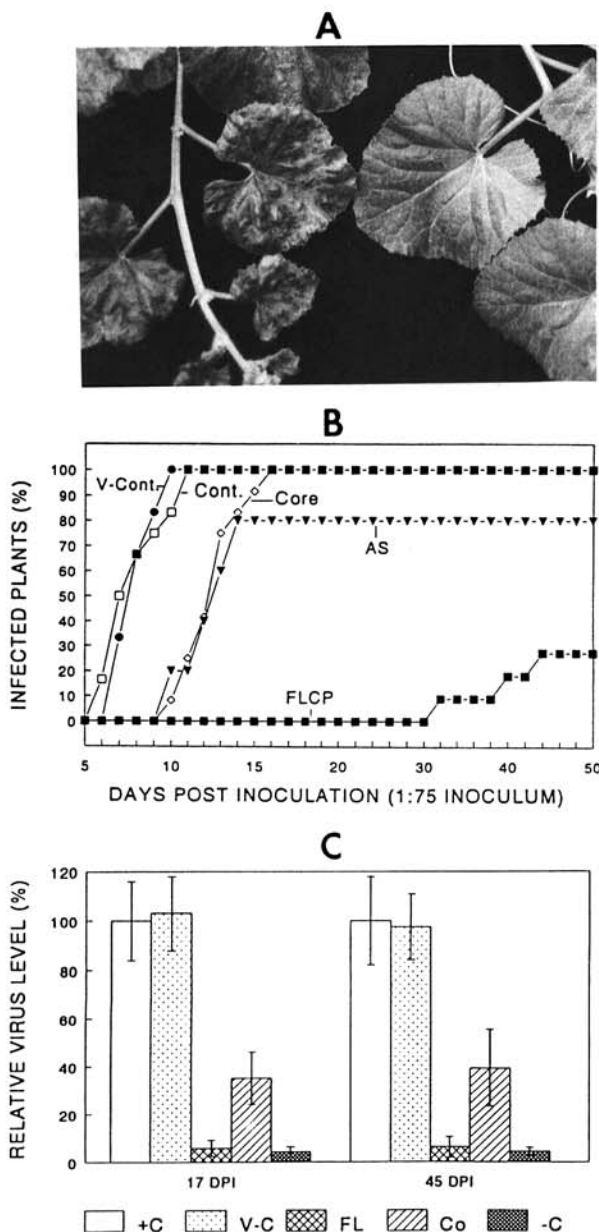
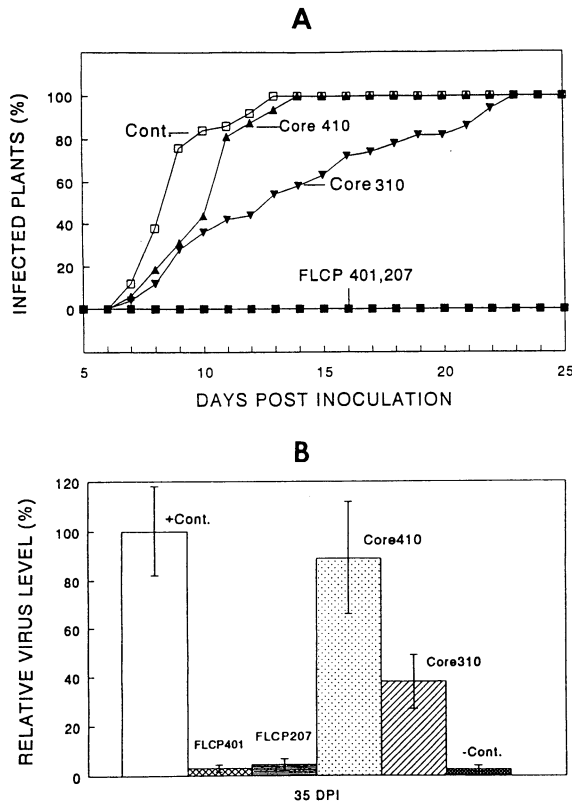

Fig. 2. Zucchini yellow mosaic virus (ZYMV) symptom development in R<sub>0</sub> transgenic melon plants inoculated with a 1:75 (w/v) homogenate of ZYMV-infected leaf tissue. **A**, Comparison of ZYMV symptom development on systemic leaves of a control, nontransformed melon plant (left), and a transgenic melon plant with the full-length ZYMV CP gene (right) at 3 wk postinoculation. **B**, Rate of symptom development of the different transgenic genotypes. Full length-coat protein (FL-CP), plants transformed with ZYMV FL-CP construct (*n* = 11); Core, plants transformed with ZYMV Core construct (*n* = 12); AS, plants transformed with ZYMV antisense CP construct (*n* = 6); V-Cont, plants transformed with the vector only (*n* = 6); and Cont, control, nontransformed plants (*n* = 12). The numbers in parentheses indicate the number of independently transformed plants. Data are combined from two experiments with the exception of V-Cont which was only tested in the first experiment. **C**, ZYMV accumulation in R<sub>0</sub> transgenic melon plants and nontransformed control plants. Duplicate leaf disk samples were obtained from upper noninoculated leaves 17 days postinoculation (dpi) and 45 dpi, and assayed for presence of ZYMV by ELISA as described in Materials and Methods. The relative virus titer in inoculated nontransformed control plants (+C) was defined as 100%. Noninoculated, nontransformed plants were used as a negative control (-C). Other samples were vector control (V-C), FL-CP (FL), and Core (Co). Data are combined from two experiments, the number of independently transformed plants of each genotype is as listed above. Bars indicate standard error.

to wild-type plants in both time of appearance (Fig. 2B) and severity of symptoms (data not shown).

Melon plants expressing ZYMV core protein showed a 3- to 10-day delay in symptom appearance. Eventually, however, all plants became infected (Fig. 2B). In most cases, the symptoms on the core-protein expressing plants were milder than for the control plants. Similar results were obtained in both experiments. Five of the six plants expressing ZYMV AS transcripts showed a delay in symptom appearance (3–9 days) and generally milder symptoms than the control plants. The sixth plant, which had the highest level of AS-RNA expression, did not develop symptoms for the duration of the experiment (90 days post-inoculation [dpi]).

In contrast to the core protein and antisense expressing plants, all of the plants producing the full-length CP (a total of 11 independently transformed R<sub>0</sub> plants tested in two experiments) showed a much higher protection level against ZYMV infection (Fig. 2B). Symptom appearance in all CP<sup>+</sup> plants was delayed for at least 30 days. Eight of the 11 plants did not show any disease symptoms for at least 90 dpi (the duration of the observation period).



**Fig. 3.** Zucchini yellow mosaic virus (ZYMV) symptom development in neomycin phosphotransferase (NPT)-positive R<sub>1</sub> progeny of transgenic melon lines FL-CP 401, 207, and Core 310 and 410. The plants were inoculated with a 1:75 (w/v) homogenate of ZYMV-infected leaf tissue. Each line included 17 plants; the control plants were not transformed. **A**, Rate of symptom development. **B**, ZYMV accumulation. Duplicate leaf disk samples were obtained from upper noninoculated leaves 35 days postinoculation (dpi), and assayed for the presence of ZYMV by ELISA. The relative virus titer (absorbance) in nontransformed control (+Cont) plants was defined as 100%, non-inoculated nontransformed plants (-Cont) were used as a negative control. Each value is the mean of 17 plants ( $\pm$  standard error).

Three of the 11 plants produced some very mild, modified symptoms 30–45 dpi.

The FL-CP expressing plants that did not develop symptoms also did not accumulate measurable virus levels (Fig. 2C). The ELISA values were not significantly different from noninoculated control plants (by analysis of variance;  $P = 0.05$ ). The virus titer in transgenic plants expressing the Core construct was intermediate between the inoculated controls and the FL-CP plants. The virus levels in the AS plants were highly variable and reflected the variability in the reaction of these plants to inoculation; e.g., one plant did not have symptoms or measurable virus levels, another had virus levels as high as controls (data not shown). The plant that did not show symptoms had the highest transcript levels. The difference in virus levels among transgenic melon plants and the control plants persisted throughout the observation period. At 45 dpi, as at 16 dpi, the mean ELISA values for the FL-CP and Core groups were significantly less than those of the controls (analysis of variance,  $P = 0.05$ ).

Resistance observed in the R<sub>0</sub> plants was also displayed in their R<sub>1</sub> progeny. All parental lines used to make R<sub>1</sub> progeny had comparable, high levels of viral protein expression (FL-CP 401, 207, and Core 310, Fig. 1C; Core 410 data not shown). All 32 NPT<sup>+</sup> progeny from the two FL-CP lines were asymptomatic during the total observation period of approximately 3 mo postinoculation (Fig. 3A), whereas the average time for symptom appearance in control plants was 10 dpi. R<sub>1</sub> progeny of Core 310 showed a delay of several days in symptom appearance. Core 410 progeny did not show a delay in symptom development, but the symptoms were milder. As with R<sub>0</sub> plants, R<sub>1</sub> plants transformed with FL-CP did not accumulate measurable virus titers (Fig. 3B). The virus levels in Core plants from line 310 were intermediate, but the virus levels in Core 410 were not significantly reduced relative to controls.

### Protection of transgenic tobacco plants against heterologous potyviruses.

The R<sub>1</sub> progeny of several transgenic tobacco lines were rub-inoculated with the heterologous potyviruses PVY and TEV. All Samsun nontransformed controls became visibly infected within 6 or 7 days of inoculation (Fig. 4). Transgenic progeny plants that did not express the NPT II gene showed the same rate of symptom appearance as the wild-type controls (data not shown). Disease symptom appearance in most of the NPT II<sup>+</sup> individuals that had been transformed with the three ZYMV CP constructs was delayed for 1–5 days relative to the controls; a few plants from the FL-CP F-7 line remained asymptomatic for 3–4 wk after inoculation with PVY (Fig. 4A). The disease symptoms in most plants were milder, and younger leaves often had no symptoms. Virus accumulation as determined by ELISA was correlated with the degree of visual symptoms (Table 1). The difference in symptoms and virus titer between most transgenic lines and the controls was persistent during the observation period of 50 dpi. The results with TEV were similar to those with PVY (compare Fig. 4A–C with D–F), and all of the transgenic genotypes (FL-CP, Core, or AS) displayed similar patterns and protection

levels.

To determine if protection in transgenic plants expressing the different forms of the ZYMV CP gene was specific to members of the potyvirus group, R<sub>1</sub> progeny were challenged with a tobamovirus, TMV. There was no obvious difference between transgenic plants expressing any of three forms of the ZYMV CP gene and the control plants in time to symptom appearance, or symptom severity in systemic leaves (data not shown).

## DISCUSSION

Three versions of the ZYMV CP gene (full-length [FL-CP], the amino-truncated core portion [Core], and anti-sense [AS]) were introduced and expressed in transgenic muskmelon and tobacco plants. Transgenic melon plants expressing the full-length ZYMV CP gene were highly resistant to infection by ZYMV. All of the independently transformed, FL-CP-expressing R<sub>0</sub> melon plants showed a very high level of protection, despite differences in CP

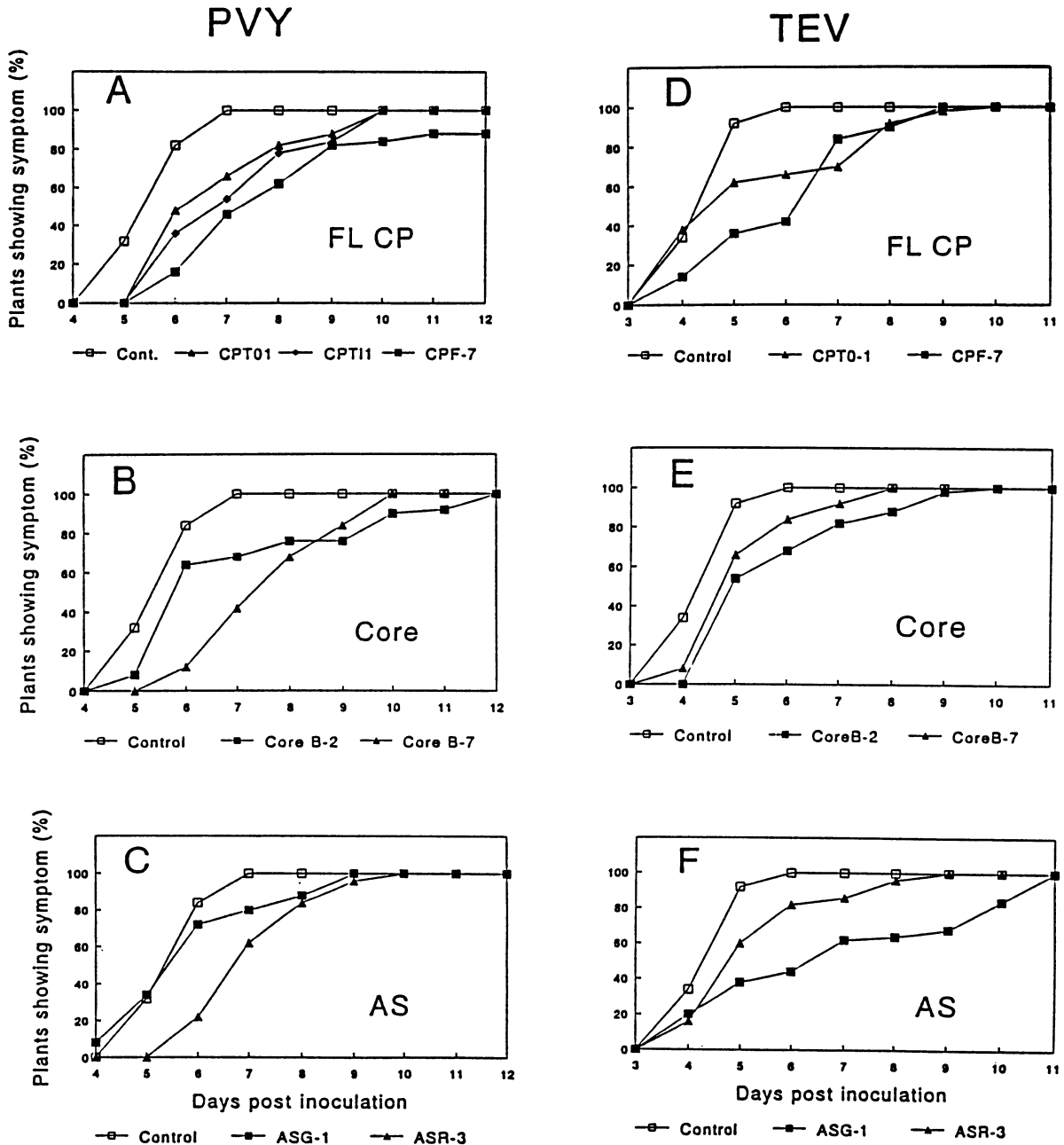

**Fig. 4.** Potato virus Y (PVY) or tobacco etch virus (TEV) symptom development in transgenic R<sub>1</sub> tobacco lines. Percentage of plants showing symptoms at daily intervals postinoculation with a homogenate of 1:20 (w/v) of PVY-(A,B,C) or 1:100 of TEV-(D,E,F) infected leaf tissue. Controls are nontransformed plants. **A, D,** Progeny of lines transformed with the zucchini yellow mosaic virus (ZYMV) full-length coat protein (FL-CP) construct. **B, E,** Progeny of lines transformed with the ZYMV Core construct. **C, F,** Progeny of lines transformed with the ZYMV antisense (AS) CP construct. The symbol used to designate each plant line is shown at the bottom of the frame. Approximately 20 R<sub>1</sub> plants from each line were inoculated.

expression levels. The majority (8/11) remained asymptomatic over 3 mo and had no measurable virus accumulation. The resistance observed in the R<sub>0</sub> plants also was evident in their R<sub>1</sub> progeny. Three months postinoculation, the R<sub>1</sub> progeny did not exhibit symptoms and had no measurable virus accumulation, whereas the average time to symptom development in the control plants was 10 dpi. Our experiments extend genetically engineered virus resistance to an additional crop species and an additional economically important potyvirus, ZYMV.

**Table 1.** Relative of virus levels of R<sub>1</sub> transgenic tobacco plants inoculated with potato virus (PVY) or tobacco etch virus (TEV)<sup>a</sup>

Line	ELISA (A <sub>405</sub> )					
	PVY		TEV			
	20 dpi	(%)	20 dpi	(%)	50 dpi	(%)
Control <sup>b</sup>	0.484 <sup>d</sup>	100	0.531 <sup>d</sup>	100	0.387 <sup>f</sup>	100
NPT <sup>-c</sup>	0.445 NS <sup>f</sup>	92	...	...	...	...
FL-CP T-0	0.239 <sup>**g</sup>	49	0.322 <sup>**</sup>	61	0.191 <sup>**</sup>	49
FL-CP T-1	0.143 <sup>**</sup>	30	...	...	...	...
FL-CP F-7	0.194 <sup>**</sup>	40	0.282 <sup>**</sup>	53	0.172 <sup>**</sup>	44
Core B-7	0.210 <sup>**</sup>	43	0.319 <sup>**</sup>	60	0.275 <sup>*</sup>	71
Core B-2	0.201 <sup>**</sup>	42	0.401 <sup>**</sup>	76	0.263 <sup>*</sup>	68
AS A-1	0.312 <sup>*</sup>	64	0.322 <sup>**</sup>	61	0.258 <sup>**</sup>	67
AS R-3	0.241 <sup>**</sup>	50	0.271 <sup>**</sup>	52	0.196 <sup>**</sup>	51

<sup>a</sup> Seedlings were rub-inoculated with inocula of PVY (1:20, w/v) or TEV (1:100, w/v).

<sup>b</sup> Nontransformed plants.

<sup>c</sup> Neomycin phosphotransferase (NPT) negative R<sub>1</sub> progeny.

<sup>d</sup> Each value is the mean of 12 samples.

<sup>e</sup> Each value is the mean of 16 samples.

<sup>f</sup> Not significantly different from control by LSD<sub>0.05</sub>.

<sup>g</sup> \*, \*\*: Significantly different from control by LSD<sub>0.05</sub> or LSD<sub>0.01</sub>, respectively.

The virus infection tests in transgenic tobacco plants showed that expression of different forms of the ZYMV CP gene also resulted in limited protection against two heterologous potyviruses, TEV and PVY. CP-mediated protection against heterologous potyviruses also has been reported for SMV-CP (Stark and Beachy 1989), PRV-CP (Ling *et al.* 1991), and WMV-2-CP and ZYMV-CP (Namba *et al.* 1992). Compared to the delays conferred by the SMV-CP and PRV-CP against TEV and PVY infection, the heterologous protection levels in our experiments were not as strong. Namba *et al.* (1992), however, found a wide range in protection levels depending on the challenging potyvirus. The differences in effectiveness against heterologous viruses may be related to the individual relationships among the different viruses.

In all but one case of genetically engineered, coat protein-mediated virus resistance, full-length coat protein genes were used. To gain insight into the mechanism of protection, and to determine whether it would be possible to confer protection against a broader range of viruses, we also tested an amino-truncated coat protein construct (the Core construct). Potyviral coat proteins have highly conserved central and carboxy terminal regions, referred to as the 'trypsin-resistant core' portion of the protein, and highly variable amino termini (Shukla and Ward 1989a). Since trypsin-treated virions appear intact in the electron microscope, and remain infectious by rub-inoculation, the CP domains that are responsible for virion assembly, CP-RNA interaction, and CP-CP interaction are thought to reside within this core (Shukla *et al.* 1988; Dougherty *et al.* 1985). It has been hypothesized that for several systems CP-mediated protection involves CP-RNA or CP-CP interaction (Beachy *et al.* 1990; Grumet 1990; Nelson *et al.*

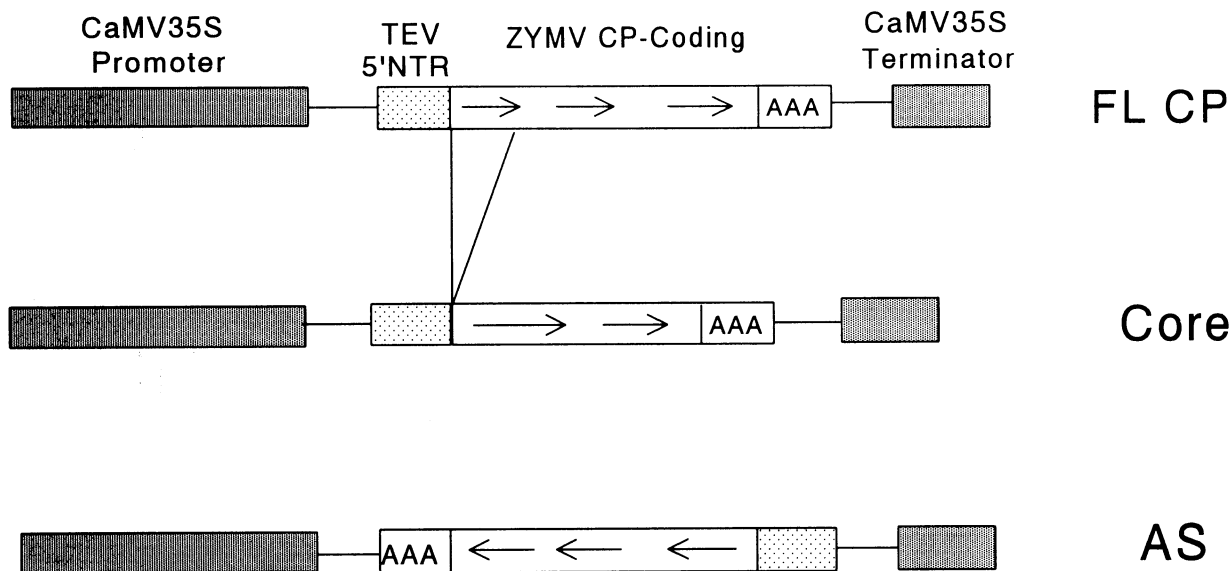

**Fig. 5.** Zucchini yellow mosaic virus coat protein (ZYMV-CP) gene constructs. Each CP-derived construct contains the *Agrobacterium tumefaciens* T-DNA left and right border sequences, the cauliflower mosaic virus 35S promoter and terminator, the tobacco etch virus (TEV) 5' nontranslated region (NTR), ZYMV-CP coding sequence, the ZYMV 3' NTR, and the selectable marker gene for kanamycin resistance, neomycin phosphotransferase (NPT II). The full length-coat protein (FL-CP) construct includes the full-length ZYMV-CP coding sequence. The Core construct contains a truncated portion of the gene encoding the central- and carboxyl-terminal region of the ZYMV CP, instead of the FL-CP. The antisense (AS) construct includes the same components as FL-CP construct, except that the TEV 5' NTR, ZYMV-CP coding sequence, and 3' NTR are in reverse orientation.



1990). If these processes are critical for protection against potyvirus infection, then the core portion of the protein would be expected to confer resistance.

Although the core portion was expressed at levels comparable to the FL-CP (e.g., Core 310 and FL-CP 401) and did confer some protection, the Core construct was not as effective as the FL-CP construct that resulted in apparent immunity to ZYMV infection. Possibly the core and amino terminus of the protein interfere with virus infection at different stages of the process, or the full-length CP may have higher affinity for viral RNA or other CP molecules than does the core. In the case of protection against the heterologous viruses TEV and PVY, both the FL-CP and Core constructs performed similarly. It may be that the function provided by the core portion or its RNA, which results in a delay in infection and reduction in virus titer, is capable of acting on more than one potyvirus. In contrast, the effect of the amino terminus, the sequence of which is virus specific, may be limited to the virus from which the CP gene was derived.

These results differ from those of Lindbo and Dougherty (1992). In their experiments, unlike those with PVY (Lawson *et al.* 1990), PPV (Regner *et al.* 1992), PRV (Fitch *et al.* 1992), and ZYMV (this paper), where full-length potyviral CP genes were very effective, the full-length TEV CP gene provided little or no protection against TEV infection. On the other hand, the TEV-CP constructs lacking C-terminal amino acids or the constructs lacking both C- and N-terminal amino acids resulted in much better protection against TEV infection than did full-length CP or constructs lacking only N-terminal amino acids. The reason(s) for the difference between these experiments is unclear.

These experiments also give insight into the possible role of the 5' and 3' nontranslated regions. Although the TEV 5' NTR may have contributed to protection overall, either by increasing the translational efficiency of the CP constructs or by interacting with the viral RNA, there did not appear to be a virus-specific effect in its interaction with TEV compared to PVY. The influence of the TEV 5' NTR alone is not known. Similarly, although the 3' NTR may have contributed to the observed resistance, it was not the only factor responsible. Although both FL-CP and Core constructs contained the complete 3' NTR and both performed equally against heterologous viruses in tobacco plants, the two constructs performed differently against the homologous virus in melon plants. We cannot eliminate the possibility that the limited protection seen in the Core constructs was actually due to the 3' NTR rather than the CP. The other potyviral constructs for which protection was conferred by a full-length CP sequence contained the potyviral 3' NTR (Stark and Beachy 1989; Lawson *et al.* 1990; Ling *et al.* 1991; Fitch *et al.* 1992; Regner *et al.* 1992). The Lindbo and Dougherty (1992) constructs did not include the potyviral 3' NTR.

Transgenic plants expressing antisense RNA of the ZYMV CP gene exhibited variable levels of protection against potyvirus infection. For both tobacco and melon, the extent of protection appeared to be correlated with transcript level. In general, however, the AS gene was less effective against ZYMV (the homologous virus) than was

the FL-CP gene in sense orientation. When tested against heterologous viruses, antisense and sense constructs performed similarly; both conferred limited protection. In most examples to date (e.g., CMV, PVX, or TMV), antisense CP genes have resulted in little or no protection (Cuozzo *et al.* 1988; Hemenway *et al.* 1988; Powell *et al.* 1989). Two exceptions were published recently, however, where it was hypothesized that the RNA conferred protection. Potato plants expressing antisense CP RNA (including 5' NTR) of potato leafroll virus (PLRV) displayed a high level of resistance to PLRV infection. The pattern and level of resistance were similar to plants producing sense RNA (Kawchuk *et al.* 1991). In transgenic tobacco plants, expression of antisense or translationally deficient sense TEV CP RNA resulted in much higher protection against TEV infection than that conferred by expression of the sense version of FL coat protein gene (Lindbo and Dougherty 1992). Further investigations are required to determine the effectiveness of this strategy in potyvirus systems.

In summary, we have demonstrated that transgenic melon plants expressing three forms of ZYMV CP gene were protected against ZYMV infection. The best protection, apparent immunity, was observed in melon plants that expressed the full-length ZYMV CP gene and were inoculated with ZYMV. Core and AS constructs were less effective. Limited protection against heterologous potyviruses was displayed in transgenic tobacco plants regardless of which construct was expressed. To evaluate further the potential usefulness of this ZYMV CP-derived resistance in cucurbits, future experiments with the ZYMV CP expressing plants will include tests against additional ZYMV strains and other cucurbit potyviruses, tests using aphid inoculation, and evaluation of field performance.

## MATERIALS AND METHODS

### Plasmid, DNA, and bacterial manipulations.

The plasmid pTL37 containing the TEV 5' nontranslated sequence (Carrington *et al.* 1987) was a gift of W. Dougherty (Oregon State University). The plasmids pRK2013 and pCIB710 and pCIB10 (Rothstein *et al.* 1987) were provided by CIBA-GEIGY Corp. (Research Triangle Park, NC). The 1,550-bp cDNA clone pZY187, which includes the ZYMV coat protein gene and 3' nontranslated region from the Connecticut strain of ZYMV, was described by Grumet and Fang (1990). Unless otherwise indicated, all recombinant DNA and bacterial manipulations were performed using standard methods (Maniatis *et al.* 1982). Restriction enzymes were purchased from Bethesda Research Laboratory (Gaithersburg, MD) or Boehringer Mannheim Biochemicals (Indianapolis, IN). *In vitro* mutagenesis was performed using an "Oligonucleotide-directed *in vitro* mutagenesis system version 2" kit (Amersham International Inc., Arlington Heights, IL). *In vitro* transcription was performed using the Riboprobe system (Promega Inc., Madison, WI). The rabbit reticulocyte lysate from Promega was used for *in vitro* translation. Polymerase chain reaction (PCR) was carried out using the GeneAmp PCR reagent kit from Perkin-

Elmer Cetus (Norwalk, CT). Manufacturers's procedures were followed for the enzymes and kits.

### ZYMV coat protein gene constructs.

Three versions of the ZYMV CP gene were engineered for transformation and expression (Fig. 5). Since potyviral proteins are expressed as polyproteins (Dougherty and Carrington 1988), *in vitro* mutagenesis was performed to introduce an ATG translation initiation codon within the context of an *NcoI* restriction site. The CP sequence in the Bluescript KS-derived plasmid pZY187 (Grumet and Fang 1990) was modified to introduce the *NcoI* site at two positions: 1) at the predicted amino terminus for the full-length CP gene (FL-CP) (primer sequence: GAGTGCCTGCCATGGGCATC; position 486–505, Grumet and Fang 1990) or 2) in a separate construction, at the beginning of the potyvirus-conserved central- and carboxyl-terminal core region of the CP gene (primer sequence: TCCTTGTCATGGTGACAGC; position 610–629). Introduction of the *NcoI* restriction site resulted in the following amino acid changes: 1) For the FL-CP construct, there were three changes, from leucine-glutamine-serine to proline-methionine-alanine. The predicted native cleavage site is between the glutamine and serine (Grumet and Fang 1990). Modifications within the CP included addition of the methionine and a change in the first amino acid of the native CP, from serine to alanine. Both serine and alanine are commonly found in the first position of potyviral coat proteins (Shukla and Ward 1989b). 2) For the core version of the CP, there was a single amino acid change from lysine to methionine at the first position within the core portion of the protein. The core version of the protein begins at the trypsin cleavage site 41 amino acids from the amino terminus, just upstream of the conserved TKDK sequence (Grumet and Fang 1990; Shukla and Ward 1989a).

The ZYMV FL-CP gene and the core region (1,052 and 939 nucleotides in length, respectively) were excised from the plasmid pZY187 as *NcoI*–*PstI* fragments which included the ZYMV 3' nontranslated region (211 nucleotides plus a poly[A] tail). The fragments were then transferred to plasmid pTL37, and linked in-frame to the ATG immediately following the TEV 5' nontranslated region (5' NTR) via the *NcoI* restriction site. The TEV 5' NTR has been shown to be a translational enhancer (Carrington and Freed 1990). Functioning of the TEV 5' NTR ZYMV CP gene constructs was verified by *in vitro* transcription from the T7 promoter and *in vitro* translation. As expected, the approximately 30-kDa FL-CP and 26-kDa Core proteins were produced (data not shown).

Fragments containing the above constructions were amplified through 10 cycles of the polymerase chain reaction (PCR) using primers designed to generate *BglII* restriction sites at each end of the fragments. The PCR-generated fragments were ligated into the *BamHI* site of plasmid pCIB710 (Rothstein *et al.* 1987) between the cauliflower mosaic virus (CaMV) 35S promoter and the CaMV 35S terminator. The resultant clones were analyzed by restriction enzyme digestion to determine the orientation of the inserts with respect to the CaMV 35S promoter and terminator. Three constructs were generated: ZYMV-FL-

CP, which contains the FL-CP gene sequence in the sense orientation; ZYMV-Core, which includes the 717 nucleotides of the conserved region of the CP gene; and ZYMV-antisense (AS), which contains the FL-CP sequence in an antisense orientation. All three constructs contain the CaMV 35S promoter, TEV 5' NTR, ZYMV 3' NTR, and CaMV 35S terminator.

The ZYMV CP gene expression cassettes were excised from plasmid pCIB710 by digestion with *XbaI* and *KpnI*, and ligated into the binary vector pCIB10 (Rothstein *et al.* 1987) adjacent to the plant-selectable marker for kanamycin resistance, the neomycin phosphotransferase (NPT II) gene. The ZYMV gene constructs and NPT II gene were located within left and right *A. tumefaciens* T-DNA borders.

### Plant transformation.

pCIB10-derived binary vectors containing the ZYMV-CP gene constructs were mobilized from *E. coli* into the disarmed *A. tumefaciens* strain LBA4404 (Hoekema *et al.* 1983) by triparental mating, using the helper plasmid pRK2013 (Comai *et al.* 1983) in *E. coli* HB101. Cotyledon pieces of muskmelon (*Cucumis melo* L. 'Hale's Best Jumbo') were transformed, regenerated, and selected according to Fang and Grumet (1990) with the following modifications. The transformed cells were selected on 125 mg of kanamycin per liter in melon regeneration (MR) medium (Neidz *et al.* 1989) containing 500 mg of carbenicillin per liter. Regenerated shoots were then placed on filter paper on a layer of liquid MS medium containing (per liter) 150 mg of kanamycin, 500 mg of carbenicillin, and 0.1 mg of benzylaminopurine for 2 wk for further selection and elongation. Elongated shoots were transferred to hormone-free rooting medium, which contained MS nutrients, (per liter) 50 mg of kanamycin, and 400 mg of carbenicillin. The rooted plantlets were transplanted into soil and grown in the greenhouse. Tobacco (*N. tabacum* 'Samsun') plants were transformed using the leaf disk protocol of Horsch *et al.* (1985).

### Analysis of transgenic plants.

Samples of leaf tissue (20–30 mg) from kanamycin-resistant regenerated plants were screened for expression of NPT II protein using double-antibody sandwich enzyme-linked immunosorbent assay (ELISA). The NPT II assay kit was purchased from 5 Prime - 3 prime, Inc. (Boulder, CO), and the assay was performed according to the manufacturer's instructions. Genomic DNA was isolated from young leaf tissue of NPT-positive plants using the high-salt procedure of Fang *et al.* (1992). Presence of the inserted ZYMV CP gene fragments was verified by PCR analysis using primers specific for the TEV 5' NTR and the ZYMV 3' NTR. Total RNA was isolated from transgenic plants essentially as described by Nagy *et al.* (1988). The RNA was separated by electrophoresis in a 1.8% agarose gel containing formaldehyde and transferred to nitrocellulose (Schleicher & Schuell Inc., Keene, NH) for Northern blot analysis. ZYMV-CP cDNA fragments were isolated from the pCIB710-ZCP plasmid and <sup>32</sup>P-labeled using a random primer DNA labeling kit (United States Biochemical Corp., Cleveland, OH). Total



soluble protein was extracted from leaf tissue of transgenic plants using the method of Powell-Abel *et al.* (1986), and the concentration was determined by the method of Bradford (1976). Protein was separated by SDS-PAGE in a 10% gel, with a known amount of purified viral CP as a standard for calculating the expression level of CP in transgenic plants. Electrophoresed proteins were electroblotted to nitrocellulose. ZYMV CP was detected using the purified IgG fraction of rabbit anti-ZYMV CP polyclonal antibodies (S. Hammar and R. Grumet, unpublished) and alkaline phosphatase-conjugated goat anti-rabbit secondary antibodies (Sigma, St. Louis, MO).

### Inoculation of transgenic plants.

To produce a set of replicate individuals for virus testing of the transgenic R<sub>0</sub> muskmelon plants, shoots were cut from transgenic and control plants and rooted in cubes of Oasis growing medium (Smithers-Oasis Co., Kent, OH). Plants at 20 days after rooting were used for the infection test. A total of 11 independently transformed FL-CP, 12 independently transformed Core, six independently transformed AS, six independently transformed vector control, and 12 nontransformed control plants were tested in two experiments. Since the time to symptom expression was the same in both experiments, the data were combined in Figure 2B. The noninoculated parent plants were self-pollinated to produce R<sub>1</sub> seed. Fifteen to seventeen NPT-expressor (NPT<sup>+</sup>) R<sub>1</sub> progeny plants from each transgenic melon line were inoculated with ZYMV at 16 days after seed germination (three- to four-leaf stage).

Transgenic R<sub>0</sub> tobacco plants (four- to five-leaf stage) were screened for resistance to virus infection, and several were allowed to self-pollinate. Approximately 10–20 NPT<sup>+</sup> R<sub>1</sub> plants from each line, 10–20 NPT<sup>-</sup> plants, and 10–20 nontransformed control plants (at 22–25 days or 32–35 days after germination) were inoculated with PVY (O strain; gift of D. Thornbury, University of Kentucky), TEV (ATCC accession PV69), or TMV (U1 strain; gift of G. DeZoeten, Michigan State University). The PVY and TEV experiments were performed three times; different R<sub>1</sub> lines were included in the different experiments. The TMV experiment was performed once.

The Connecticut strain of ZYMV was maintained and increased in zucchini (*Cucurbita pepo* 'Black Jack') plants. TEV, TMV, and PVY were propagated and maintained in tobacco (*Nicotiana tabacum* 'Samsun') plants. Inocula were made from infected zucchini or tobacco by homogenizing leaf tissue in 20 mM potassium phosphate buffer, pH 7.0. The homogenate was diluted to a specific concentration (gram of leaf tissue per milliliter of buffer volume): PVY (1:20), TEV (1:100) and TMV (1:100). For ZYMV, 1:50 and 1:75 dilutions were used.

Plants were dusted with 400-mesh Carborundum on the two youngest expanded leaves and rubbed with viral inocula. The inoculated plants were observed daily for systemic disease symptom development. Periodically after inoculation the two youngest fully expanded leaves (generally the uppermost second and third leaves) were sampled to test for systemic virus accumulation by indirect ELISA. The procedure was based on Romaine *et al.* (1981). The antibodies were: anti-ZYMV antibody raised against

ZYMV virions (Ct strain, S. Hammar and R. Grumet, unpublished), antibody against PVY (Agdia Inc., Elkhart, IN), and a general antibody against the potyvirus group (Agdia Inc.), for detecting TEV. Leaf disk samples were placed in microtiter plates, frozen (at –80° C) and thawed twice, and then incubated in coating buffer at 4° C for 16 hr. Samples were reacted with a 1:1,000 (ZYMV or PVY) or 1:100 (TEV) dilution of antibodies for 2 hr at 37° C, followed by incubation with alkaline phosphatase-goat anti-rabbit antibody conjugate (Sigma, St. Louis, MO) for 2 hr at 37° C. *p*-Nitrophenyl-phosphate substrate was added and the absorbance (405 nm) monitored using a Datatech plate reader.

### ACKNOWLEDGMENTS

We would like to thank Bill Dougherty for providing the pTL37 plasmid, Georgia Helmer and CIBA-GEIGY for providing the pCIB10 and pCIB710 vectors, and Gus DeZoeten and Dave Thornbury for providing viral inocula. We thank Sue Hammar for assistance with the ELISAs, Jae Min Lee for producing melon cuttings and performing melon crosses, and Richard Allison, Gus DeZoeten, Jim Hancock, and Mike Thomashow for critical reading of the manuscript. This work was in part supported by grants from the Campbell Research Institute, the Pickle Seed Research Institute, and the Rackham Foundation. Acknowledgment is also made to the Michigan Agricultural Experiment Station for their support of this research.

### LITERATURE CITED

- Bradford, M. M. 1976. A rapid and sensitive method for the quantitation of microgram quantities of proteins utilizing the principle of protein-dye binding. *Anal. Biochem.* 72:248-254.
- Beachy, R. N., Loesch-Fries, S., and Tumer, N. E. 1990. Coat protein-mediated resistance against virus infection. *Annu. Rev. Phytopathol.* 28:451-474.
- Carrington, J. C., and Freed, D. D. 1990. Cap-independent enhancement of translation by a plant potyvirus 5' nontranslated region. *J. Virol.* 64:1590-1597.
- Carrington, J. C., Parks, T. D., Cary, S. M., and Dougherty, W. G. 1987. Vectors for cell-free expression and mutagenesis of protein coding sequences. *Nucleic Acids Res.* 15:10066.
- Comai, L., Schilling-Cordavo, C., Mergia, A., and Houck, C. M. 1983. A new technique for genetic engineering of *Agrobacterium* Ti plasmid. *Plasmid* 10:21-30.
- Cuozzo, M., O'Connell, K. M., Kaniewski, W., Fang, R.-X., Chua, N.-H., and Tumer, N. E. 1988. Viral protection in transgenic tobacco plants expressing the cucumber mosaic virus coat protein or its antisense RNA. *Bio/Technology* 6:549-557.
- Davis, R. F., and Mizuki, M. K. 1985. Detection of cucurbit viruses in New Jersey. *Plant Dis.* 71:40-44.
- Dougherty, W. G., and Carrington, J. C. 1988. Expression and function of potyviral gene products. *Annu. Rev. Phytopathol.* 26:123-143.
- Dougherty, W. G., Willis, L., and Johnston, R. E. 1985. Topographic analysis of tobacco etch virus capsid protein epitopes. *Virology* 144:66-72.
- Fang, G. W., and Grumet, R. 1990. *Agrobacterium tumefaciens* mediated transformation and regeneration of muskmelon plants. *Plant Cell Rep.* 9:160-164.
- Fang, G., Hammar, S., and Grumet, R. 1992. A quick and inexpensive method for removing polysaccharides from plant genomic DNA. *Bio/Techniques* 13:52-54.
- Fitch, M. M., Manshardt, R. M., Gonsalves, D., Slightom, J. L., and Sanford, J. C. 1992. Virus resistant papaya plants derived from tissues bombarded with the coat protein gene of papaya ringspot virus. *Bio/Technology* 10:1466-1472.
- Gal-On, A., Antignus, Y., Rosner, A., and Raccach, B. 1990. Nucleotide sequence of zucchini yellow mosaic virus capsid-encoding gene

- and its expression in *Escherichia coli*. *Gene* 87:273-277.
- Grumet, R. 1990. Genetically engineered plant virus resistance. *HortScience* 25:508-513.
- Grumet, R., and Fang, G. W. 1990. cDNA cloning and sequence analysis of the 3'-terminal region of zucchini yellow mosaic virus RNA. *J. Gen. Virol.* 71:1619-1622.
- Hemenway, C., Fang, R.-X., Kaniewski, J. J., Chua, N.-H., and Tumer, N. E. 1988. Analysis of the mechanism of protection in transgenic plants expressing the potato virus X coat protein or its antisense RNA. *EMBO J.* 7:1273-1280.
- Hoekema, A., Hirsch, P. R., Hooykass, P. J. J., and Schilperroof, R. A. 1983. A binary strategy based on separation of *vir* and T-region of the *Agrobacterium tumefaciens* Ti plasmid. *Nature* 303:179-190.
- Horsch, R. B., Fry, J. E., Hoffman, N. L., Wallroth, M., Eichholz, D., Rogers, S., and Fraley, R. T. 1985. A simple and general method for transferring genes into plants. *Science* 227:1229-1231.
- Kawchuk, L. M., Martin, R. R., and McPherson, J. 1991. Sense and antisense RNA-mediated resistance to potato leafroll virus in Russet Burbank potato plants. *Mol. Plant-Microbe Interact.* 4:247-253.
- Lawson, C., Kaniewski, W., Haley, L., Rozman, R., Newell, C., Sanders, P., and Tumer, N. E. 1990. Engineering resistance to mixed virus infection in a commercial potato cultivar: Resistance to potato virus X and potato virus Y in transgenic Russet Burbank. *Bio/Technology* 8:127-134.
- Lindbo, J. A., and Dougherty, W. G. 1992a. Pathogen-derived resistance to a potyvirus: Immune and resistant phenotypes in transgenic tobacco expressing altered forms of a potyvirus coat protein nucleotide sequence. *Mol. Plant-Microbe Interact.* 5:144-153.
- Ling, K., Namba, S., Gonsalves, C., Slightom, J. L., and Gonsalves, D. 1991. Protection against detrimental effects of potyvirus infection in transgenic tobacco plants expressing the papaya ringspot virus coat protein gene. *Bio/Technology* 9:752-758.
- Lisa, V., Boccardo, G., D'Agostino, G., Dellavalle, G., and D'Aquilio, M. 1981. Characterization of a potyvirus that causes zucchini yellow mosaic. *Phytopathology* 71:667-672.
- Maniatis, T., Fritsch, E. F., and Sambrook, J. 1982. *Molecular Cloning: A Laboratory Manual*. Cold Spring Harbor Laboratory Press, Cold Spring Harbor, NY.
- Namba, S., Ling, K., Gonsalves, C., Slightom, J. L., and Gonsalves, D. 1992. Protection of transgenic plants expressing the coat protein gene of watermelon mosaic virus or zucchini yellow mosaic virus against six potyviruses. *Phytopathology* 82:940-946.
- Nagy, F., Kay, S. A., and Chua, N. H. 1988. Analysis of gene expression in transgenic plants. Pages B4 1-29 in: *Plant Molecular Biology Manual*. S. B. Gelvin and R. A. Schilperooft, eds. Kluwer Academic Publishers, Dordrecht, the Netherlands.
- Neidz, R. R., Smith, S. S., Dunbar, K. B., Stephens, C. T., and Murakishi, H. H. 1989. Factors influencing shoot regeneration from cotyledonary explants of *Cucumis melo*. *Plant Cell Tissue Organ Cult.* 18:313-319.
- Nejdat, A., and Beachy, N. 1990. Transgenic tobacco plants expressing a coat protein gene of tobacco mosaic virus are resistant to some other tobamoviruses. *Mol. Plant-Microbe Interact.* 3:247-251.
- Nelson, R. S., Powell-Abel, P., and Beachy, R. N. 1987. Lesions and virus accumulation in inoculated transgenic tobacco plants expressing the coat protein gene of tobacco mosaic virus. *Virology* 158:126-132.
- Nelson, R. S., Powell, P. A., and Beachy, R. N. 1990. Coat protein-mediated protection against virus infection. Pages 13-24 in: *Genetic Engineering of Crop Plants*. G. W. Lycett and D. Grierson, eds. Butterworths, Kent, UK.
- Powell-Abel, P., Nelson, R. S., De, B., Hoffman, N., Rogers, S. G., and Beachy, R. N. 1986. Delay of disease development in transgenic plants that express the tobacco mosaic virus coat protein gene. *Science* 232:738-743.
- Powell, P., Stark, D. M., Sanders, P. R., and Beachy, R. N. 1989. Protection against tobacco mosaic virus in transgenic plants that express TMV antisense RNA. *Proc. Natl. Acad. Sci. USA* 86:6949-6952.
- Quemada, H., Sieu, L. C., Siemieniak, D. R., Gonsalves, D., and Slightom, J. L. 1990. Watermelon mosaic virus II and zucchini yellow mosaic virus: Cloning of 3'-terminal regions, nucleotide sequences, and phylogenetic comparisons. *J. Gen. Virol.* 71:1451-1460.
- Regner, F., Machado, A. C., Machado, M. L. C., Steinkellner, H., Mattanovich, D., Hanzer, K., Weiss, H., and Katinger, H. 1992. Coat protein mediated resistance to plum pox virus in *Nicotiana glauca* and *N. benthamiana*. *Plant Cell Rep.* 11:30-33.
- Romaine, C. P., Newhart, S. R., and Anzola, D. 1981. Enzyme-linked immunosorbent assay for plant viruses in intact leaf tissue disks. *Phytopathology* 71:308-312.
- Rothstein, S. J., Lahners, K. N., Lotstein, R. J., Carozzi, N. B., Jayne, S. M., and Rice, D. A. 1987. Promoter cassettes, antibiotic-resistance genes, and vectors for plant transformation. *Gene* 53:153-161.
- Shukla, D. D., and Ward, C. W. 1989a. Structure of potyvirus coat protein and its application in the taxonomy of the potyvirus group. *Adv. Virus Res.* 36:273-314.
- Shukla, D. D., and Ward, C. W. 1989b. Identification and classification of potyviruses on the basis of coat protein sequence data and serology. *Arch. Virol.* 106:171-200.
- Shukla, D. D., Strike, P. M., Tracy, S. L., Gough, K. H., and Ward, C. W. 1988. The N- and C-termini of the coat protein of potyviruses are surface located and the N-terminus contains the major virus-specific epitopes. *J. Gen. Virol.* 69:1497-1503.
- Stark, D. M., and Beachy, R. N. 1989. Protection against potyvirus infection in transgenic plants: Evidence for broad spectrum resistance. *Bio/Technology* 7:1257-1262.